

INSTRUCTIONS FOR USE

HBsAg

VITROS Immunodiagnostic Products HBsAg Reagent Pack

REF

680 1322

CAUTION: Federal law restricts this device to sale by or on the order of a physician.

Intended Use

For the *in vitro* qualitative detection of hepatitis B surface antigen (HBsAg) in human serum and plasma (heparin, EDTA, and sodium citrate) using the VITROS Eci/ECiQ Immunodiagnostic System.

Assay results, in conjunction with other serological and clinical information, may be used for the laboratory diagnosis of individuals with acute or chronic hepatitis B. In addition, this assay may be used to screen for hepatitis B infection in pregnant women to identify neonates who are at high risk of acquiring HBV during the perinatal period.

WARNING: *This assay has not been FDA cleared or approved for the screening of blood or plasma donors. Assay performance characteristics have not been established when the VITROS HBsAg assay is used in conjunction with other manufacturers' assays for specific HBV serological markers. Users are responsible for establishing their own performance characteristics.*

Summary and Explanation of the Assay

Viral hepatitis is a major public health problem of global importance with an estimated 300 million persistent carriers of hepatitis B virus (HBV) worldwide.¹ Infection with HBV results in a wide spectrum of acute and chronic liver diseases that may lead to cirrhosis and hepatocellular carcinoma.²

Viral hepatitis is a disease of the liver that is caused by a number of well-characterized viruses including HBV.³ Transmission of HBV occurs by percutaneous exposure to blood products and contaminated instruments, sexual contact and perinatally from HBV-infected mothers to their unborn child.⁴

HBV infection produces an array of unique antigens and antibody responses that, in general, follow distinct serological patterns. Hepatitis B surface antigen (HBsAg), derived from the viral envelope, is the first antigen to appear following infection and can be detected serologically as an aid in the laboratory diagnosis of acute HBV infection.

Detection of HBsAg by sensitive enzyme immunoassays was described by Engvall and Perlmann,⁵ Engvall, Jonsson and Perlmann,⁶ and VanWeemen and Schuur⁷ in 1971. Subsequently, solid-phase sandwich enzyme immunoassays for the detection of HBsAg were described by Wisdom,⁸ Wolters et al.,⁹ and Wei et al.¹⁰ Production, characterization and application of monoclonal antibodies^{11, 12} for the detection of HBsAg have also been described.

Principles of the Procedure

The VITROS HBsAg assay is performed using the VITROS HBsAg Reagent Pack and VITROS Immunodiagnostic Products HBsAg Calibrator on the VITROS Eci/ECiQ Immunodiagnostic System (VITROS Immunodiagnostic System).

An immunometric technique is used. This involves the simultaneous reaction of HBsAg in the sample with mouse monoclonal anti-HBs antibody coated onto the wells and a horseradish peroxidase (HRP)-labeled mouse monoclonal anti-HBs antibody in the conjugate. Unbound conjugate is removed by washing.

A reagent containing luminogenic substrates (a luminol derivative and a peracid salt) and an electron transfer agent, is added to the wells.¹³ The HRP in the bound conjugate catalyzes the oxidation of the luminol derivative, producing light. The electron transfer agent increases the level and duration of the light produced. The light signals are read by the VITROS Immunodiagnostic System. The amount of HRP conjugate bound is indicative of the level of HBsAg present in the sample.

Assay Type	Assay Time and Temperature	
Immunometric assay	Incubation time	29 minutes
	Time to first result	37 minutes
	Temperature	37°C

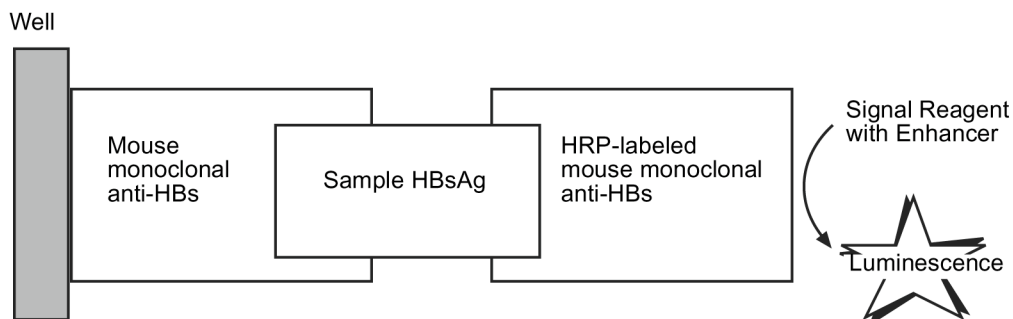
Reaction Scheme**Warnings and Precautions**

For *in vitro* diagnostic use only.

WARNING: Potentially Infectious Material

Human blood products provided as components of this pack have been obtained from donors who were tested individually and found to be negative for HBsAg, and for antibodies to human immunodeficiency virus (HIV 1+2) and hepatitis C virus (HCV), using FDA approved methods (enzyme immunoassays, EIA). The VITROS HBsAg Calibrator contains human HBsAg purified from donors who were tested individually and found to be negative for antibodies to HIV 1+2 and HCV (using EIA). The purified HBsAg has been heat inactivated (10 hours at 60 °C). Treat as if capable of transmitting infection

Care should be taken when handling material of human origin. All samples should be considered potentially infectious. No test method can offer complete assurance that hepatitis B virus, HCV, HIV 1+2 or other infectious agents are absent. Handling of samples and assay components, their use, storage and disposal should be done at a biological safety level 2 and be in accordance with the procedures defined by the appropriate biohazard safety guideline or regulation.^{14, 15}

WARNING: Contains Kathon

The reagents contain Kathon. R43: May cause sensitization by skin contact. R52/53: Harmful to aquatic organisms, may cause long-term adverse effects in the aquatic environment. S24: Avoid contact with skin. S37: Wear suitable gloves.

Reagents**Reagent Pack Contents**

One VITROS HBsAg Reagent Pack; 100 tests (CAT No. 680 1322) contains:

- 100 coated wells (mouse monoclonal anti-HBs (directed to the "a" region determinant), coated at 1 µg/well)
- 6.2 mL conjugate reagent (HRP- mouse monoclonal anti-HBs, 0.9 µg/mL) in buffer with bovine serum albumin, goat serum, and antimicrobial agent (Kathon 1% w/v)
- 8.4 mL assay reagent with human serum, newborn calf serum, mouse serum, and antimicrobial agent (Kathon 1% w/v)

Reagent Pack Handling

- The reagent pack is supplied ready for use.
- Reagent packs do not need mixing.
- Avoid agitation, which may cause foaming or the formation of bubbles.

Reagent Pack Stability

When stored and handled as specified in the package labeling, the VITROS HBsAg Reagent Pack is suitable for use until the expiration date printed on the outside of the carton.

Reagent Pack Storage and Preparation

- Store the unopened reagent pack refrigerated at 2–8 °C (36–46 °F). Do not freeze.
- Load reagent packs directly from refrigerated storage to minimize condensation.
- Use opened reagent packs within 8 weeks.
- Store opened reagent packs in the VITROS Immunodiagnostic System reagent supply, or refrigerated at 2–8 °C (36–46 °F) in a sealed reagent pack storage box that contains dry desiccant.
- Exposure of Reagent Pack and Calibrator to temperatures >30 °C (86 °F) for extended periods of time may affect assay performance.

Specimen Collection and Preparation

Patient Preparation

No special patient preparation is necessary.

Recommended Specimen Types

Serum, EDTA, heparin, or citrated plasma.

Heparin and citrate have been shown to lower the signal/cutoff (s/c) values in some HBsAg reactive samples. High negative results (0.80–0.99 s/c) obtained on samples collected with these anticoagulants should be interpreted accordingly. Supplemental tests may be required. Follow manufacturer's instructions for using plasma collection containers with anticoagulants.

Specimens Not Recommended

Turbidity in samples may affect assay results.

Special Precautions

Some sample collection devices have been reported to be detrimental to the integrity of certain analytes, and could interfere with some method technologies.¹⁶ Because of the variety of sample collection devices available, it is not possible to issue a definitive statement on the performance of VITROS Immunodiagnostic Products when used with these devices. Each user should confirm that the chosen device is used according to the manufacturer's instructions and is compatible with this assay.

Specimen Collection and Preparation

- Collect specimens using standard procedures.¹⁷
- The VITROS HBsAg assay uses 80 µL of sample for each determination.
- For details on minimum fill volume of sample cups or containers, refer to the VITROS ECi/ECiQ Immunodiagnostic System Operator's Guide.
- Mix samples, calibrators, and controls by inversion and bring to 15–30 °C (59–86 °F) before use.
- Samples should be thoroughly separated from all cellular material. Failure to do so may lead to a falsely elevated result.

Handling and Storage Conditions

- Handle specimens in stoppered containers to avoid cross-contamination and evaporation. Use a separate disposable tip if samples are manually pipetted. Avoid splashing, forming an aerosol, or cross-contaminating sample tube stoppers.
- The amount of time samples are on board the VITROS Immunodiagnostic System prior to analysis should be limited to avoid evaporation. This time should not exceed two hours. Refer to the VITROS ECi/ECiQ Immunodiagnostic System Operator's Guide for further information.
- The National Committee for Clinical Laboratory Standards (NCCLS) provides the following recommendations for storing blood specimens:¹⁸
 - Store samples at 22° C (72° F) for no longer than 8 hours.
 - If the assay will not be completed within 8 hours, refrigerate the sample at 2–8 °C (36–46 °F).
 - If the assay will not be completed within 48 hours, or for shipment of samples, freeze at or below –20 °C (–4 °F).
- Samples are not to be repeatedly frozen and thawed because this can cause analyte deterioration. Samples are to be thawed only once.

Assay Procedure

Materials Required But Not Provided

The following items are required to perform the VITROS HBsAg assay:

- VITROS Immunodiagnostic System
- VITROS HBsAg Calibrator
- VITROS Immunodiagnostic Products Signal Reagent
- VITROS Immunodiagnostic Products Universal Wash Reagent
- Quality control materials, such as VITROS Immunodiagnostic Products HBsAg Controls
- VITROS Immunodiagnostic Products Reagent Pack Storage Box (optional) with desiccant

Operating Instructions

Refer to the VITROS ECi/ECiQ Immunodiagnostic System Operator's Guide for complete instructions on the operation of your VITROS Immunodiagnostic System.

Calibration

Required Calibrators

VITROS HBsAg Calibrator

Calibrator Preparation, Handling, and Storage

Refer to the calibrator instructions for use for information on the use of VITROS HBsAg Calibrator.

Calibration Procedure

- Calibration must be performed using a calibrator of the same lot number as the reagent pack.
- Refer to the VITROS ECi/ECiQ Immunodiagnostic System Operator's Guide for detailed instructions on how to calibrate.

When to Calibrate

- Calibrate when the lot of reagent pack and calibrator changes
- Calibrate every 28 days

The VITROS HBsAg assay may also need to be calibrated:

- After specified service procedures have been performed (see the VITROS ECi/ECiQ Immunodiagnostic System Operator's Guide)
- If quality control results are consistently outside of the manufacturer's or your acceptable range

For additional information on when to calibrate, refer to the VITROS ECi/ECiQ Immunodiagnostic System Operator's Guide.

Quality Control

Procedure Recommendations

- Choose control levels that check performance at clinically relevant points. The recommendation is to run a negative control and a positive control close to the HBsAg decision point (signal/cutoff ≥ 1.00).
- To verify system performance, analyze control materials:
 - After calibration
 - At least once every 24 hours
 - After specified service procedures or maintenance to critical parts or subsystems that might influence performance of the assay (see the VITROS ECi/ECiQ Immunodiagnostic System Operator's Guide)
- Analyze quality control materials in the same manner as patient specimens.
- If control results fall outside the stated range or outside your established acceptable range, patient results should not be reported. Investigate and determine the cause for the unacceptable control results. When the condition is corrected, retest the controls and confirm that results are within acceptable limits. It is advisable to repeat some or all patient specimens before reporting results for this run.
- For more detailed information on quality control procedures, refer to the VITROS ECi/ECiQ Immunodiagnostic System Operator's Guide.
- Refer to *Internal Quality Control Testing: Principles and Definitions* or other published guidelines for general quality control recommendations.¹⁹
- Additional controls may be tested according to guidelines or requirements of local, state, and/or federal regulations or accrediting organizations.

Quality Control Material Selection

Choose control material that has a composition similar to or identical with the patient sample matrix being analyzed.²⁰

VITROS HBsAg Controls are recommended for use with the VITROS Immunodiagnostic System. The performance of other commercial control fluids should be evaluated for compatibility with this assay before they are used for quality control.

Appropriate quality control value ranges should be established for all commercially available quality control materials used with the VITROS HBsAg assay.

Quality Control Material Preparation and Storage

Refer to the manufacturer's product literature for preparation, storage, and stability information.

Interpretation of Results and Expected Results

Results are calculated as a normalized signal, relative to the cutoff value (signal/cutoff, s/c). During the calibration process, a lot-specific parameter, encoded on the lot calibration card, is used to determine a valid stored cutoff value for the VITROS Immunodiagnostic System.

$$\text{Result} = \frac{\text{Signal for test sample}}{\text{Cutoff value}}$$

Patient sample results will be displayed with a "Negative", "Retest?", or "Positive" label. An initial result labeled with "Retest?" indicates a sample that requires repeat testing for HBsAg.

Result (s/c)	< 0.90	≥ 0.90 and ≤ 5.00	> 5.00
Result Text	Negative	Retest?	Positive

Final results should be manually interpreted using the algorithm below.

Testing Algorithm

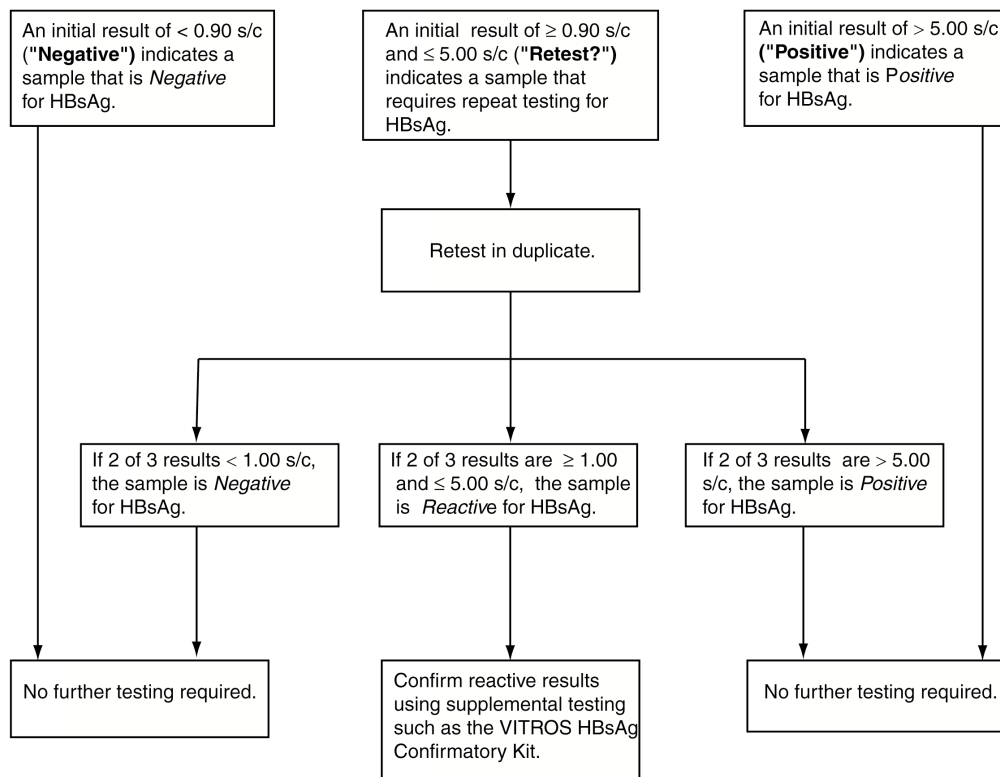

Interpretation of Results

The following table summarizes the interpretation of results obtained with the VITROS HBsAg assay upon completion of all testing steps required in the testing algorithm.

Final VITROS HBsAg Assay Result (s/c)	Conclusion from Testing Algorithm	Interpretation
< 1.00	Negative	Specimen is presumed to be negative for HBsAg.
≥ 1.00 and ≤ 5.00	Reactive	Specimen is reactive for HBsAg. If a reactive result is confirmed by supplemental tests, such as the VITROS Immunodiagnostic Products HBsAg Confirmatory Kit, the specimen is positive for HBsAg.
> 5.00	Positive	Specimen is positive for HBsAg. *

* In instances where HBsAg is used as a stand alone assay (for example in pregnant women being screened to identify neonates who are at risk for acquiring HBV during the perinatal period), supplemental testing such as the VITROS HBsAg Confirmatory Kit should be used to confirm the result.

- The magnitude of a VITROS HBsAg assay result cannot be correlated to an endpoint titer.
- The ability of the VITROS HBsAg assay to detect HBV mutants has not been determined. Testing using alternative methodologies may be warranted if signs, symptoms, and risk factors are indicative of viral hepatitis and other laboratory tests are nonreactive for the diagnosis of viral hepatitis.
- Heparin and citrate have been shown to lower the signal/cutoff (s/c) values in some HBsAg reactive samples. High negative results (0.80–0.99 s/c) obtained on samples collected with these anticoagulants should be interpreted accordingly. Supplemental tests may be required.

Expected Results

Approximately 66.1% (1439/2177) of the prospective subjects participating in the VITROS HBsAg clinical study were asymptomatic and reported no recent or current signs or symptoms of hepatitis. Of these individuals, 20.9% were enrolled in Miami, FL, 46.1% were enrolled in Dallas, TX, 32.6% were enrolled in Chicago, IL, and 0.4% were enrolled in New York, NY. The group was Caucasian (28%), African American (46%) Hispanic (18%), and Asian (4%) with the remaining 4% represented by three or more ethnic groups. The group was 54% male and 46% female and ranged in age from 5 to 96 years. All were at risk for viral hepatitis due to lifestyle, behavior, occupation or known exposure event. The VITROS HBsAg assay was positive in 3.3% of the individuals in this group. The percent VITROS HBsAg positive results observed in the asymptomatic population at each site was 4.3% at Miami, FL, 3.5% at Dallas, TX, 2.0% at Chicago, IL, and 20% at New York, NY.

The table below summarizes the percent VITROS HBsAg positive and negative results by gender and age range.

Age Range	Gender	VITROS HBsAg Result				Total
		+		-		
		n	Percent	n	Percent	
0-9	F	0	NA	0	NA	0
	M	0	NA	1	100	1
10-19	F	2	11	16	89	18
	M	0	NA	11	100	11
20-29	F	1	1	122	99	123
	M	2	2	110	98	112
30-39	F	1	1	149	99	150
	M	18	8	214	92	232
40-49	F	3	2	154	98	157
	M	10	4	235	96	245
50-59	F	3	3	106	97	109
	M	4	4	101	96	105
60-69	F	0	NA	67	100	67
	M	3	7	42	93	45
70-79	F	0	NA	27	100	27
	M	0	NA	26	100	26
80-89	F	0	NA	5	100	5
	M	0	NA	2	100	2
90-100	F	0	NA	0	100	0
	M	0	NA	1	100	1
Total		47		1389		1436*

* Age was not reported for three subjects.

Limitations of the Procedure

- Heterophilic, e.g. human anti- mouse, antibodies in the serum or plasma of certain individuals are known to cause interference with immunoassays.²¹ These antibodies may be present in blood samples from individuals regularly exposed to animals or who have been treated with animal serum products.
- Individuals recently vaccinated for hepatitis B may give a transient positive result for HBsAg because of its presence in the vaccine.²²
- HBsAg results should only be used and interpreted in the context of the overall clinical picture. A negative test result does not exclude the possibility of exposure to or infection with hepatitis B virus. Levels of HBsAg may be undetectable both in early infection and late after infection. In rare cases HBsAg tests do not detect certain HBV mutant strains.²³
- The analytical sensitivity of the VITROS HBsAg assay was determined to be 0.085 IU/mL World Health Organization (WHO) 1st International Reference Standard 80/549), 0.030 PEI Units/mL (commercial ad subtype sensitivity panel), and 0.019 PEI Units/mL (commercial ay subtype sensitivity panel).
- Assay performance characteristics have not been established for any other specimen matrices than serum or heparin, EDTA, and sodium citrate anticoagulated plasma.
- The results from this or any other diagnostic kit should be used and interpreted only in the context of the overall clinical picture.
- It has been shown that up to 498 µg HBsAg/mL does not create a high dose hook effect that will interfere with this assay.

Performance Characteristics

Clinical Performance

A multi-center prospective study was conducted to evaluate the clinical performance of the VITROS HBsAg assay with individuals with signs or symptoms of hepatitis. Also included were individuals at high risk of HBV infection due to lifestyle, behavior, occupation, or known exposure events. Specimens were obtained from collection sites located in Miami, FL (32%), Dallas, TX (36%), Chicago, IL (30%), and New York, NY (2%).

The group was Caucasian (27%), African American (44%), and Hispanic (22%), with the remaining 7% represented by other ethnic groups. The group was 54% male and 46% female and ranged in age from five to 96 years. The HBV disease classification for each subject was determined by a single point serological assessment using a hepatitis marker profile consisting of reference assays (previously licensed or approved by the FDA) for the detection of HBsAg, HBeAg, anti-HBc, anti-HBc IgM, anti-HBe, and anti-HBs (quantitative). All reference assays used were from a single manufacturer. The reference assays' procedures were adhered to during the clinical laboratory study. Testing of these specimens occurred at hospital associated diagnostic laboratories located in Miami, FL (32%), Dallas, TX (36%), and Port Jefferson, NY (32%). Agreement of the VITROS HBsAg assay was assessed relative to the reference HBsAg confirmed results and the specimen classification using serum samples from 2156 of the 2177 subjects enrolled.*

Results by Specimen Classification

The data were analyzed following the assignment of specimen classification based upon the positive (+) / negative (-) patterns for the six HBV serological reference markers. The table below summarizes how these classifications were derived. There were 24 unique reference marker patterns observed in the VITROS HBsAg clinical study.

HBV Reference Markers						HBV Classification
HBsAg*	HBeAg	IgM Anti-HBc	Total Anti-HBc	Anti-HBe	Anti-HBs (≥10 mIU/mL)	
+	+	+	+	+	-	Acute
+	+	+	+	-	-	Acute
+	-	+	+	+	-	Acute
+	-	-	-	-	-	Acute
+	+	-	+	+	-	Chronic
+	+	-	+	-	-	Chronic
+	-	-	+	+	+	Chronic
+	-	-	+	+	-	Chronic
+	-	-	+	-	-	Chronic
-	-	+	+	+	+	Early Recovery
-	-	+	+	+	-	Early Recovery
-	-	+	+	-	+	Early Recovery
-	-	+	+	-	-	Early Recovery
-	-	-	+	+	-	Early Recovery
-	-	-	+	+	+	Recovery
-	-	-	+	-	+	Recovered
-	-	-	+	-	-	Recovered
-	-	-	-	-	+	HBV Vaccine Response
-	-	-	-	-	-	Not Previously Infected
+	-	-	-	-	+	Uninterpretable
-	+	-	+	-	-	Uninterpretable
-	+	-	-	-	+	Uninterpretable
-	+	-	-	-	-	Uninterpretable
-	-	+	-	-	-	Uninterpretable

* Positive (+) = Reference HBsAg assay reactive and confirmed by neutralization. Negative (-) = Reference HBsAg assay negative or not confirmed by neutralization.

* HBV disease classification could not be determined for 21 of the 2177 subjects due to incomplete reference marker profiles (missing one or more results for the panel of six HBV reference markers). These 21 subjects were excluded from the analysis.

Comparison of Results

The table below compares the VITROS HBsAg results with the reference HBsAg results by specimen classification for the prospective sample population.

Disease Classification	Final Reference HBsAg Assay Result *				Total
	- **		+		
	Final VITROS HBsAg Result				
	-	+	-	+	
Acute Infection	0	0	5***	20	25
Chronic Infection	0	0	2	51	53
Early Recovery	64	1	0	0	65
Recovery	184	0	0	0	184
Recovered	266	2	0	0	268
Uninterpretable	11	0	1	1	13
HBV Vaccine Response	236	0	0	0	236
Not Previously Infected with HBV	1304	8	0	0	1312
Grand Total	2065	11	8	72	2156

* Final reference HBsAg assay result is based on the initial test result, and confirmatory testing of repeatedly reactive samples.

** Fourteen specimens were reactive with the initial reference HBsAg assay, but did not confirm (3 - recovery, 2 - HBV vaccine response, 9 - not previously infected with HBV). All other specimens were nonreactive for the reference HBsAg assay.

*** These five samples were positive only for the reference HBsAg assay. Four of these patients had normal ALT levels and showed no clinical signs or symptoms of HBV infection. Their clinical presentation was not consistent with the results of the reference HBsAg assay. Taking the clinical symptoms and normal ALT levels into consideration the negative VITROS HBsAg result appears to be more consistent with their clinical presentation. The remaining sample where HBsAg was the only marker detectable also showed elevated ALT levels and was reference assay anti-HCV positive.

The results are broken out further where initial VITROS HBsAg results required repeat testing and confirmation (s/c ≥ 1.00 and ≤ 5.00), and positive samples where no further VITROS testing was required (s/c > 5.00).

Samples with Two of Three VITROS HBsAg Initial and Repeat Test Results ≥ 1.00 and ≤ 5.00					
Disease Classification	Final Reference HBsAg Assay Result *				Total
	+		-		
	VITROS HBsAg Interpretation Following VITROS HBsAg Confirmatory Testing				
	+	NT**	+	-	
Acute Infection	0	1	0	0	1
Chronic Infection	1	0	0	0	1
Early Recovery	0	0	0	1	1
Not Previously Infected with HBV	0	0	2	1	3
Grand Total	1	1	2	2	6

* Final reference HBsAg assay result is based on the initial test result, and confirmatory testing of repeatedly reactive samples.

** VITROS HBsAg Confirmatory Testing was not performed.

Samples with Initial or Two of Three VITROS HBsAg S/C results ≥ 5.00 where VITROS HBsAg Confirmatory Testing was not Required			
Disease Classification	Final Reference HBsAg Assay Result*		Total
	+	-**	
	Final VITROS HBsAg Result		
	+	+	
Acute Infection	19	0	19
Chronic Infection	50	0	50
Recovered	0	2	2
Uninterpretable	1	0	1
Not Previously Infected with HBV	0	5	5
Grand Total	70	7	77

* Final reference HBsAg assay result is based on the initial test result, and confirmatory testing of repeatedly reactive samples.

** Initial reference HBsAg assay result was negative.

Percent Agreement

The table below summarizes the percent agreement between the VITROS HBsAg assay and the reference HBsAg assay for each specimen classification for the prospective sample population. The table provides the 95% exact confidence interval.

HBV Classification	Positive Percent Agreement	95% Exact Confidence Interval	Negative Percent Agreement	95% Exact Confidence Interval
Overall	90.00 (72/80)	81.24–95.58	99.47 (2065/2076)	99.05–99.74
Acute	80.00 (20/25)	59.30–93.17	NA	NA
Chronic	96.23 (51/53)	87.02–99.54	NA	NA
Early Recovery	NA	NA	98.46 (64/65)	91.72–99.96
Recovery	NA	NA	100.0 (184/184)	98.02–100.0
Recovered	NA	NA	99.25 (266/268)	97.33–99.91
Uninterpretable	50.00 (1/2)	1.26–98.74	100.0 (11/11)	71.51–100.0
HBV Vaccine Response	NA	NA	100.0 (236/236)	98.45–100.0
Not Previously Infected	NA	NA	99.39 (1304/1312)	98.80–99.74

Percent Agreement of the VITROS HBsAg Assay for Subjects with Clinically Diagnosed Acute or Chronic HBV Infection

The performance of the VITROS HBsAg assay was further evaluated among archived serum samples from subjects based on documented clinical status or diagnosis of acute (demonstrated seroconversion or HBV reference marker profile) or chronic (HBsAg present for ≥ 6 months) HBV infection. Samples were obtained prospectively and from commercial and site archives. The table below summarizes the percent agreement of the VITROS HBsAg assay in samples from subjects with documented acute or chronic HBV infection.

HBV Infection	Number of Samples	Number (%) of VITROS HBsAg Positive Samples	95% Exact Confidence Interval
Acute	38	36* (94.7)	82.25–99.36
Chronic	32	32 (100.0)	88.43–100.0
Total	68	66 (97.1)	89.78–99.64

* The two acute samples negative by the VITROS HBsAg assay were obtained from patients undergoing seroconversion to HBsAg positive status. Occasional discrepancies may occur between different manufacturer's HBsAg assays when testing samples during early seroconversion.

Seroconversion Panels

Seventeen HBV seroconversion panels were obtained from two commercial vendors (6280–6293 and PHM920–PHM933). These panels were obtained from donors in the early stages of seroconversion from HBsAg negative to HBsAg positive status and contained individual samples in which HBsAg was the only detectable HBV marker, as determined by historical HBV marker data provided by the manufacturers.

The table below presents a summary of the results of testing of the 17 panels with the VITROS and reference HBsAg assays.

Panel ID	Days to HBsAg Reactive Result from Initial Draw Date		Difference in Days to HBsAg Reactive Result (Reference – VITROS)
	Reference HBsAg Assay	VITROS HBsAg Assay	
6280	13	13	0
6282	26	19	7
6283	37	29	8
6284	50	50	0
6285	45	45	0
6286	40	36	4
6287	68	68	0
6288	21	14	7
6289	36	36	0
6290	21	21	0
6291	34	27	7
6292	35	35	0
6293	15	23	-8
PHM920	26	26	0
PHM921	0	0	0
PHM922	16	16	0
PHM933	9	7	2

Clinical Performance in Pregnant Women

Prospectively collected and archived serum samples from healthy, pregnant women at low risk or high risk for exposure to HBV were tested to assess the clinical performance of the VITROS HBsAg assay in screening for hepatitis B infection to identify neonates at high risk of acquiring HBV during the perinatal period.^{24,25} A total of 545 samples were prospectively collected during the clinical study in several different locations in the US. An additional 199 frozen archived samples were obtained from a commercial vendor. These frozen archived samples had been prospectively collected from women at low risk for viral hepatitis in several different locations in the US. Of the combined 744 prospectively collected and archived samples, 52% were obtained in Florida, 24% were obtained in Texas, 23% were obtained in California and 1% were obtained in Connecticut. Of the combined population, 35.9% were obtained during the first trimester, 34.1% during the second trimester and 30.0% during the third trimester. The following table furnishes a breakdown of the study population.

Demographic Profiles of Pregnant Women at Low or High Risk for Viral Hepatitis			
Risk	Low N (%)	High N (%)	Total N (%)*
TOTAL**	463 (62.2)	281 (37.8)	744 (100)
TRIMESTER			
First	200 (43.2)	67 (23.8)	267 (35.9)
Second	152 (32.8)	102(36.3)	254 (34.1)
Third	111(24.0)	112 (39.9)	223 (30.0)
ETHNICITY***			
Caucasian	269 (58.1)	17 (6.0)	286 (38.4)
African-American	53 (11.4)	75 (26.7)	128 (17.2)
Hispanic	125 (27.0)	158 (56.2)	283 (38.0)
Asian	7 (1.5)	1 (0.4)	8 (1.1)
Indian	1 (0.2)	4 (1.4)	5 (0.7)
Haitian	1 (0.2)	16 (5.7)	17 (2.3)
Other	7 (1.5)	6 (2.1)	13 (1.7)
Unknown	0 (0)	4 (1.4)	4 (0.5)
AGE (Years)***			
11-30	268 (57.9)	182 (64.8)	450 (60.5)
31-50	194 (41.9)	99 (35.2)	293 (39.4)
Unknown	1 (0.2)	0 (0)	1 (0.1)

* The total number (N) of subjects at both low and high risk belonging to the variable category in the left hand column; expressed as a percentage (%) of all analyzed subjects (N=744).

** The number (N) of subjects at low or high risk; expressed as a percentage (%) of analyzed subjects (N=744)

*** The number (N) of subjects at low or high risk belonging to the variable category in the left hand column; expressed as a percentage (%) of all subjects at low or high risk.

Agreement of the VITROS HBsAg assay was assessed relative to the reference HBsAg results using serum samples obtained from a total of 744 women at low risk or high risk for HBV infection. The tables below compare the VITROS and reference HBsAg assays among the overall population of pregnant women by risk and trimester.

VITROS and Reference HBsAg Results Among Low Risk Pregnant Women									
VITROS HBsAg Result	First Trimester			Second Trimester			Third Trimester		
	Reference HBsAg Result		Total	Reference HBsAg Result		Total	Reference HBsAg Result		Total
	+	-		+	-		+	-	
+	2	0	2	0	0	0	0	0	0
-	0	198	198	0	152	152	0	111	111
Total	2	198	200	0	152	152	0	111	111

VITROS and Reference HBsAg Results Among High Risk Pregnant Women									
VITROS HBsAg Result	First Trimester			Second Trimester			Third Trimester		
	Reference HBsAg Result		Total	Reference HBsAg Result		Total	Reference HBsAg Result		Total
	+	-		+	-		+	-	
+	1	0	1	1	0	1	1	0	1
-	0	66	66	0	101	101	0	111	111
Total	1	66	67	1	101	102	1	111	112

Overall VITROS and Reference HBsAg Results Among Pregnant Women

Frequency of Reactivity of the VITROS HBsAg Assay in Pregnant Women

The table below summarizes the frequency of reactivity of the VITROS HBsAg assay from a total of 744 women at low risk and high risk for HBV infection.

VITROS HBsAg Result	Reference HBsAg Result		Total N (%)
	+	-	
+	5 (100)	0 (0.0)	5 (0.7)
-	0 (0.0)	739 (100)	739 (99.3)
Total	5 (0.7)	739 (99.3)	744 (100)

Positive and Negative Percent Agreement of the VITROS and Reference HBsAg Assays in Pregnant Women

The table below summarizes the percent agreement between the VITROS HBsAg assay and the reference HBsAg assay for this population. The table provides the 95% exact confidence intervals.

Subjects	Positive Percent Agreement	95% Exact Confidence Interval	Negative Percent Agreement	95% Exact Confidence Interval
Pregnant Women	100 (5/5)	47.82–100.0	100.0 (739/739)	99.50–100.0

Performance of Neonate Serum

In order to determine if neonate serum may be tested with the VITROS HBsAg assay, cord blood was used as a surrogate for neonate serum. A total of 60 individual cord blood and ten individual serum samples were tested in the VITROS HBsAg assay. In testing the cord blood samples, 0 out of 60 were found to give a reactive result. None of the serum samples were initially reactive. Upon spiking the cord blood samples with HBsAg to a target of 2.0 s/c, 58 out of 60 samples gave a reactive result. Two samples were found to contain a significant amount of anti-HBs. These two specimens were not evaluated due to the HBsAg result being below the reactive level. To remove systematic bias, each serum sample mean was evaluated to each cord blood mean. The table below shows the amount of bias for the cord blood samples from serum.

	Negative and Positive Percent (%) HBsAg Cord Blood Bias Related to Serum					
	(+/-) 0-10	(+/-) 11-20	(+/-) 21-30	(+/-) 31-40	(+/-) 41-50	(+/-) ≥51
n Mean S/CO	41	10	4	2	1	0
Percent Mean S/CO	70.7	17.2	6.9	3.4	1.7	0.0

Potentially Cross-Reacting Subgroups

The specificity of the VITROS HBsAg assay was evaluated by testing 249 samples from 16 potentially cross-reacting subgroups. All of the samples were previously classified as HBsAg negative in other commercially available assays. Samples found to be ≥ 1.00 by the VITROS HBsAg assay were retested in duplicate. A summary of the results is given in the table below.

Clinical Category	Number Samples Tested	VITROS HBsAg Assay Result <1.00	VITROS HBsAg Assay Result ≥ 1.00
Hepatitis A Infection (HAV)	10	9	1*
Hepatitis C Infection (HCV)	10**	10	0
Hepatitis E Infection (HEV)	10	10	0
Non-viral Liver Disease ***	50	50	0
Autoimmune Diseases (Rheumatoid Arthritis / Systemic Lupus Erythematosus)	60	60	0
Cytomegalovirus (CMV)	7	7	0
Epstein-Barr Virus (EBV)	10	10	0
Herpes Simplex Virus (HSV) (HSV1 and HSV2 not distinguished)	10	10	0
Parvovirus B19 Infection	10	10	0
Rubella	11	11	0
Syphilis	16	16	0
Toxoplasmosis	10	10	0
Human Immunodeficiency Virus (HIV 1/2)	10	10	0
Human T-cell Lymphotropic Virus (HTLV 1/2)	10	10	0
Heterophilic Antibodies (Human anti-mouse)	5	5	0
Recent Influenza Vaccine Recipients	10	10	0
Total Samples Tested	249	248	1

* Classified as falsely reactive. The sample did not demonstrate the $\geq 50\%$ neutralization required to be classified as positive.

** Two of these samples were repeatedly aHCV reactive by EIA and strip immunoblot assay (SIA) positive.

*** Samples were obtained from individuals with elevated liver enzymes, alcoholic liver disease, and liver cancer.

The specificity of the VITROS HBsAg assay was evaluated further by testing samples from the following additional potentially cross-reacting sub-groups: HCV (bDNA positive), HIV-1 (PCR positive), and HIV-2 (antibody positive). Additionally, testing was performed on serum samples spiked with *Toxoplasma gondii tachyzoites* (whole and sonicated), *Staphylococcus aureus*, *Escherichia coli* and *Pseudomonas aeruginosa*. Samples were tested with and without an additional spike of HBsAg at a s/c of 2.00 ± 1.00 . The spiked and unspiked samples were assayed in triplicate.

Of the samples tested, none of the unspiked samples were observed to be false reactive and none of the HBsAg spiked samples were observed to be false negative in the VITROS HBsAg assay.

Substances that do not Interfere

As recommended by NCCLS Protocol EP7, ²⁶ the VITROS HBsAg assay was evaluated for interference by testing the substances listed in the table below. Testing was performed using matched pairs of negative donor serum and negative donor serum spiked with HBsAg at a target s/c of 2.00 ± 1.00 with two lots of reagent. None of the compounds at the levels tested were found to interfere with the clinical interpretation of the assay.

Compound	Compound Concentration	
Bilirubin	0.35 mmol/L	20 mg/dL
Hemoglobin	0.31 mmol/L	500 mg/dL
Triolein	33.9 mmol/L	3000 mg/dL

Analytical Sensitivity

Detection of a known level of HBsAg is a function of the assay's analytical sensitivity (that is, the dependency of the assay result on the HBsAg level) as well as the assay precision. To examine the analytical sensitivity of the VITROS HBsAg assay, three standard series with known levels were evaluated. Duplicate determinations of each panel member were obtained using three lots of reagents. The HBsAg level at the assay's cutoff was estimated from a linear regression analysis.

Series	Cutoff (s/c = 1.00)	95% Exact Confidence Interval
WHO 1st International Reference Standard, 80/549	0.085 IU/mL	0.051 - 0.118
Boston Biomedica Inc. HBsAg Sensitivity panel (ad subtype), PHA 805	0.030 PEI* Units/mL	0.007 - 0.054
Boston Biomedica Inc. HBsAg Sensitivity panel (ay subtype), PHA 805	0.019 PEI* Units/mL	0.008 - 0.029

* Paul Ehrlich Institute

As a demonstration of performance of subtype detection, the VITROS HBsAg assay tested with the French ADM SFTS 1996 Sensitivity panel is presented below. The panel contains 20 individual samples representing 10 subtypes with a known, predetermined HBsAg concentration. Single determinations of the panel members with the VITROS HBsAg assay were made. The VITROS HBsAg assay demonstrated detection of all subtypes in the French ADM SFTS 1996 Sensitivity panel. Ten panel members consisted of the more common ad/ay subtype. Nine panel members represented the less commonly encountered subtypes and are depicted in the graph below.

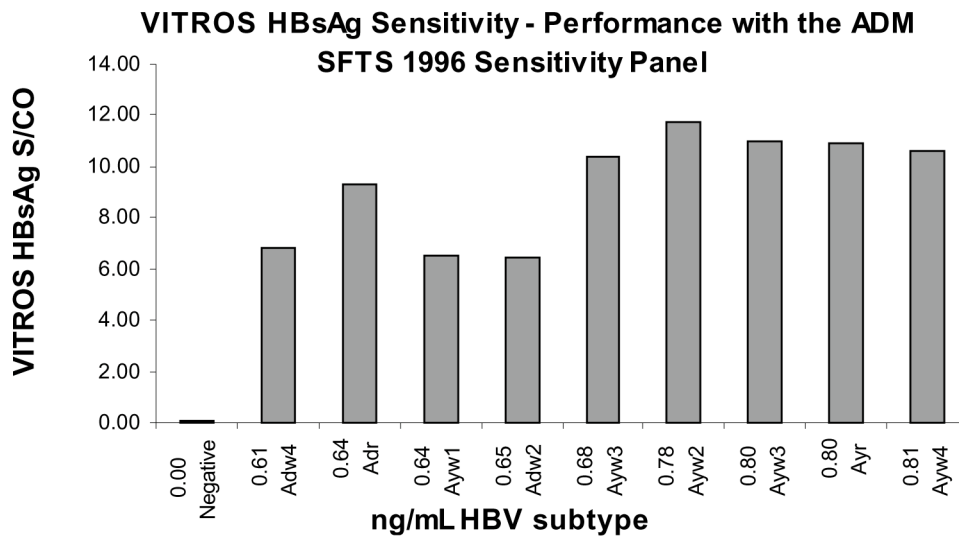

Precision

Precision was evaluated on a different VITROS Immunodiagnostic System at three external sites using one lot of reagent. With one exception, at least two replicates each of a three member panel were assayed on a single occasion per day on up to 20 different days. The data shown in the table were rounded following all calculations.

	Mean VITROS HBsAg S/C (Ratio)	Within Day*		Between Day**		Total***		No. Observ.	No. Days
		SD	CV (%)	SD	CV (%)	SD	CV (%)		
Site 1	0.11	0.015	14.5	0.023	21.6	0.027	26.0	42	20
	0.75	0.024	3.2	0.035	4.7	0.043	5.7	39	20
	3.05	0.123	4.0	0.239	7.8	0.269	8.8	42	20
Site 2	0.11	0.014	12.4	0.029	25.7	0.032	28.5	40	20
	0.84	0.019	2.3	0.038	4.6	0.043	5.1	40	20
	3.17	0.047	1.5	0.063	2.0	0.079	2.5	40	20
Site 3	0.13	0.028	21.2	0.015	11.3	0.032	24.0	41	20
	0.84	0.022	2.6	0.051	6.0	0.055	6.6	40	20
	3.10	0.048	1.5	0.084	2.7	0.097	3.1	41	20

* **Within Day:** Variability of the assay performance from replicate to replicate.

** **Between Day:** Variability of the assay performance from day to day.

*** **Total:** Variability of the assay performance combining the effects of within day and between day.

Precision was further evaluated incorporating between site and between lot variation. The study was performed at three external sites using three reagent lots. At least five replicates each of a four member panel were assayed on a single occasion per day on six different days. The between site, between lot, and total precision estimates (CV) were derived from a variance component analysis. The data shown in the table were rounded following all calculations.

Mean VITROS HBsAg S/C (Ratio)	Between Site*		Between Lot**		Total***		No. Observ.
	SD	CV (%)	SD	CV (%)	SD	CV (%)	
0.87	0.058	6.7	0.055	6.4	0.094	10.8	270
0.93	0.057	6.2	0.048	5.1	0.090	9.7	269****
1.07	0.066	6.2	0.051	4.8	0.106	9.8	270
4.06	0.049	1.2	0.183	4.5	0.249	6.1	270

* **Between site:** Variability of the assay performance from site to site.

** **Between lot:** Variability of the assay performance from lot to lot, calculated using data across all sites

*** **Total:** Variability of the assay performance incorporating factors of site, lot, and day.

**** One gross outlier (>21 SDs from the mean) in 270 observations (0.37%) was excluded from this calculation.

The data presented in both studies are a representation of assay performance and are based on the studies described. Variables such as sample handling and storage, reagent handling and storage, laboratory environment, and system maintenance can affect the reproducibility of assay results.

References























1. Maynard JE. et al. In Zuckermann AJ. (ed), *Viral Hepatitis and Liver Disease*. New York: Alan R. Liss Inc; 1988; 967-969.
2. Beasley RP, Hwang L. In Vyas GN. (ed), *Viral Hepatitis and Liver Disease*. New York: Grune & Stratton; 1984; 209-224.
3. Hollinger FB, Dienstag J. Hepatitis B and D viruses. In: Murray T, Baron E, Phaller M, Tenover F, Tenover R (eds). *Manual of Clinical Microbiology*. Washington DC: American Society for Microbiology Press, 1995:1033-1049.
4. Ganem D. Hepadnaviridae and their replication. In: Fields B, Knipe D, Howley P, eds. *Fields Virology*. Philadelphia: Lippencott-Raven Publishers, 1996:2703-2737.
5. Engvall E, Perlmann P. Enzyme-linked immunosorbent assay (ELISA): Quantitative assay of immunoglobulin G. *Immunochem.* 8:871-874; 1971.
6. Engvall E, Jonsson K, Perlmann P. Enzyme-linked Immunosorbent Assay II. Quantitative Assay of protein antigen, immunoglobulin G, by means of enzyme-labeled antigen and antibody-coated tubes. *Biochem. Biophys. Acta.* 251:427-434; 1971.
7. VanWeemen BK, Schuur AHWM. Immunoassay using enzyme-antigen conjugates. *FEBS Letters.* 15:232-236; 1971.
8. Wisdom GB. Enzyme-Immunoassay. *Clin. Chem.* 22:1243-1255; 1976.
9. Wolters G, Kuijpers L, Kacaki J, Schuur A. Solid-phase enzyme immunoassay for detection of hepatitis B surface antigen. *J Clin Pathol.* 29:873-879; 1976.
10. Wei R, Knight GJ, Zimmerman DH, Bond HE. Solid-phase enzyme immunoassay for hepatitis B surface antigen. *Clin. Chem.* 23:813-815; 1977.
11. Goodall AH, Meischer G, Meek FM, Janossy G, Thomas HC. Monoclonal antibodies in a solid-phase radiometric assay for HBsAg. *Med Lab Sci.* 38:349-354; 1981.
12. Shih JW-K, Cote PJ, Dapolito GM, Gerin JL. Production of monoclonal antibodies against hepatitis B surface antigen (HBsAg) by somatic cell hybrids. *J Virol Meth.* 1:257-273; 1980.

Glossary of Symbols

13. Summers M et al. Luminogenic Reagent Using 3-Chloro 4-Hydroxy Acetanilide to Enhance Peroxidase/Luminol Chemiluminescence. *Clin Chem.* 41:S73; 1995.
14. CDC-NIH. *Biosafety in Microbiological and Biomedical Laboratories – 3rd Edition.* HHS Publication No. (CDC) 93-8395. U.S. Government Printing Office, Washington, D.C., 1993.
15. CLSI. Protection of Laboratory Workers from Occupationally Acquired Infections; Approved Guideline– Third Edition. CLSI. document M29-A3 (ISBN 1-56238-567-4). CLSI. 940 West Valley Road, Suite 1400, Wayne, Pennsylvania 19087–1898 USA, 2005
16. Calam RR. Specimen Processing Separator Gels: An Update. *J Clin Immunoassay.* 11:86–90; 1988.
17. NCCLS. *Procedures for the Collection of Diagnostic Blood Specimens by Venipuncture – Third Edition; Approved Standard.* NCCLS document H3-A3 (ISBN 1-56238-108-3). NCCLS, 940 West Valley Road, Suite 1400, Wayne, Pennsylvania 19087, 1991.
18. NCCLS. *Procedures for the Handling and Processing of Blood Specimens; Approved Guideline – Second Edition.* NCCLS document H18-A2 (ISBN 1-56238-388-4). NCCLS, 940 West Valley Road, Suite 1400, Wayne, Pennsylvania 19087; 1999.
19. NCCLS. *Internal Quality Control: Principles and Definitions; Approved Guideline.* NCCLS document C24-A (ISBN 1-56238-112-1). NCCLS, 940 West Valley Road, Suite 1400, Wayne, Pennsylvania 19087; 1991.
20. NCCLS. *Internal Quality Control Testing for Quantitative Measurements: Principles and Definitions: Approved Guidelines-Second Edition.* NCCLS document C24-A2 (ISBN 1-56238-371-X), NCCLS, 940 West Valley Road, Suite 1400. Wayne, Pennsylvania 19087, 1999.
21. Levinson SS. The Nature of Heterophilic Antibodies and Their Role in Immunoassay Interference. *J Clin Immunoassay.* 15:108–115; 1992.
22. Kloster B, Kramer R, Eastlund T, Grossman B, Zarvan B. Hepatitis B surface antigenemia in blood donors following vaccination. *Transfusion.* 35:475–477; 1995.
23. Carmen WF. The clinical significance of surface antigen variants of hepatitis B virus. *Journal of Viral Hepatitis.* 4 (Suppl.1):11–20; 1997.
24. CDC. Epidemiologic Notes and Reports. Maternal Hepatitis B Screening Practices-California, Connecticut, Kansas, and United States, 1992–1993. *MMWR.* 43(17):311, 317–320; 1994.
25. CDC. Program to Prevent Perinatal Hepatitis B Virus Transmission in a Health-Maintenance Organization-Northern California, 1990–1995. *MMWR.* 46(17):378–380; 1997.
26. NCCLS. *Interference Testing in Clinical Chemistry; Proposed Guideline.* NCCLS document EP7-P (ISBN 1-56238-020-6). NCCLS, 940 West Valley Road, Suite 1400, Wayne, Pennsylvania 19087, 1986.

Glossary of Symbols

The following symbols may have been used in the labeling of this product.

	Do Not Reuse		Authorized Representative in the European Community		Corrosive
	Use by or Expiration Date (Year-Month-Day)		Contains Sufficient for "n" Tests		Flammable
	Lot Number		Upper Limit of Temperature		Fragile, Handle with Care
	Serial Number		Lower Limit of Temperature		Keep Dry
	Catalog Number or Product Code		Temperature Limitation		This end up
	Attention: See Instructions for Use		Consult Instructions for Use, "n" Version		Der Grüne Punkt (the Green Dot). Manufacturer follows certain packaging material waste disposal management regulations
	Manufacturer		Irritant		
	<i>In vitro</i> Diagnostic Medical Device		Harmful		

Revision History

Date of Revision	Version	Description of Technical Changes*
2006-08-25	2.0	<ul style="list-style-type: none"> • <i>Intended Use – Warning:</i> Removed “Assay performance characteristics have not been established for testing of newborns.” • <i>Warnings and Precautions:</i> Updated format and added the Kathon warning • <i>Reagent Pack Contents</i> – removed asterisks for Lots below Lot 5500 • <i>Performance Characteristics</i> - Added <i>Performance of Neonate Serum</i> section. • Added Glossary of Symbols table • References – updated reference 15. • Changed “VITROS ECi Immunodiagnostic System” to VITROS ECi/ECiQ Immunodiagnostic System” • Changed all occurrences of “VITROS ECi System Operator’s Guide” to “VITROS ECi/ECiQ Immunodiagnostic System Operator’s Guide”. • Changed all occurrences of “VITROS ECi System” to “VITROS Immunodiagnostic System”
2002FEB28	1.0	<ul style="list-style-type: none"> • New format. • Update to 2001JUN28 – Reagent Pack Contents – Testing Algorithm

* The change bars indicate the position of a technical amendment to the text with respect to the previous version of the document.

When this Instructions For Use is replaced, sign and date below and retain as specified by local regulations or laboratory policies, as appropriate.

Signature _____
Obsolete Date

Conditions of supply: all supplies are made subject to the standard terms and conditions of Ortho-Clinical Diagnostics or its distributors. Copies of these are available on request.

Co-developed with

CHIRON

CHIRON Corporation
Emeryville, CA 94608-2916



Ortho-Clinical Diagnostics
Johnson & Johnson
50-100 Holmers Farm Way
High Wycombe
Buckinghamshire
HP12 4DP
United Kingdom



Ortho-Clinical Diagnostics

a Johnson & Johnson company

VITROS is a trademark of Ortho-Clinical Diagnostics, Inc.
© Ortho-Clinical Diagnostics, Inc. 2002 2006